



גשרים



חוברת 63

בפרויקט "נשאים בבית"

של חיים כ"ץ

תוכלו לפנות אלי למייל info@gisha-center.com

ולהירשם לקבלת חוברות פעילות אתגריות

מידי יום בתקופת הקורונה

השימוש הוא אישי בלבד, ולא מוסדי

או ארגוני.

אהבתם?

בכדי שנוכל להמשיך הלאה, אנו צריכים

תמיכה כספית בפרויקט

דברו איתי.

כל הזכויות שמורות

חיים כץ מטפל באמצעות הרפתקה, מנחה סדנאות,

רעיונאי ויוצר.



סדנאות ODT



העצמה



רענון



חוויות



שיפור



גיבוש



מסעות



שטח



גשרים

לפני שלוש שנים התפרסמו לראשונה תשבצי הגשרים (האשי ביפנית) הם התקבלו ע"י חובבי חידות הגיון ותשבצים בהתלהבות רבה.

לפניכם מספר תשבצי גשרים

והנה הכללים (מתוך המכלול)

- המספר הכתוב בעיגול מציין את מספר הגשרים שנמתחים מהאי.
- אסור לגשרים לחצות גשרים אחרים או איים.
- הגשרים יכולים להיות מוצבים אך ורק במאונך או במאוזן.
- בין כל זוג איים יכולים לחבר עד שני גשרים.
- על הגשרים לחבר בין כל האיים (כלומר, שיהיה אפשר להגיע מכל אי לכל אי).

הנה לכם תשבץ אחד פתור, שתוכלו להתבונן בו ולהבין!

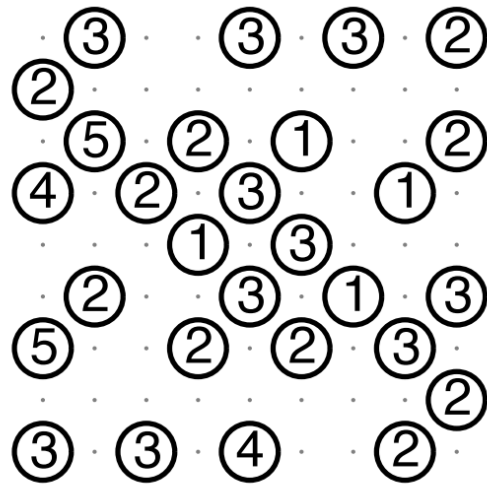
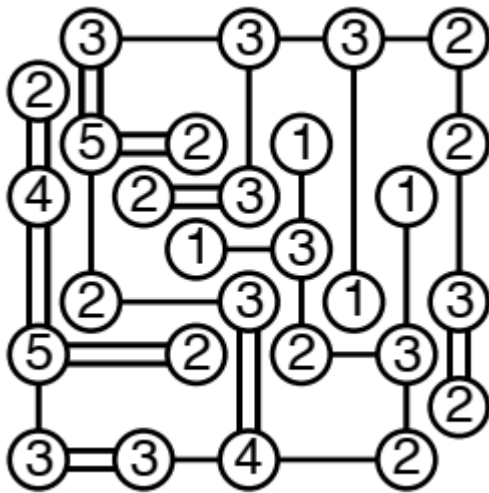

בהצלחה





2	2	5	2	
			1	3
6	3			
	2	6	1	
3	1		2	6
	2			
1	3	5		3
	2	3		2

	2	6	2	1
3		3		
		5	5	4
	2	3	1	
5		5		2
	1		2	
4		3		3
	2	3	1	
3		2	3	2





3	2	2	1		
3	4				
3	4	6	7	3	1
2	5	5	6	1	3
1	3	6			3
2		2		1	

1	3	3	3	3	3	
1	5	5	4	6	3	3
3	6	8	5	5	3	2
1				1	3	
3	2	4	3	3	3	2
4	1	4	3	3	1	
2						
4	5	5	6	7	5	
1	1	5	5	6	4	3
3	3	3	3	2	1	



סדנאות ODT



העצמה



רענון



חוויות



שיפור



גיבוש



מסעות



שטח



סדנאות ODT



העצמה



רענון



חוויות



שיפור



גיבוש



מסעות



שטח

3	3	3		3	3		2	1		
3		1	3		6	5	5	4	2	
	3	2		1				8	4	
3	3	4	4	3	7	4	6			
3	3	4	4	1		1	1			
	2		2	2	5		2	2	4	3
3	4		1		2	2	2	4	3	
	5		6	6		4			1	
1					1		2		4	
2	3	4		3	5		3			
1	2	3		6	5		8	7		6
2	3	3	3						1	
	4	5		4	5		6	5		
2	4	6		4			1			3
		1		6	6		1		2	
	2	5	2	1		3	2			2
2	1	3	6	8	3			1		
	1	2				1	5	7		4
1	3	4	4	4		4	1			
		3	3	3	3		2	2	3	2



סדנאות ODT

A large grid of 100 circles, arranged in 10 rows and 10 columns. Each circle contains a number from 1 to 7. The numbers are distributed as follows:

2	2	3	2	2	1	1	3		
	3		1					2	1
1		1		4	1	4	7	3	
	1		3		2		1		3
	3		2		4	1	2	4	6
3		5		4	3	5	4	1	
	1		2		1				3
3		6		5	3				
	3		2		3		1	4	3
			3		5		4	3	5
	3		6		2		2		3
3			3		4		6		5
	4		6		3		4		2
2		4		5	2		3		6
	3				1		2		2
			1		3		4		1
			4		1		4		4
2		4		6	4		3		5
	3				3		3		2
			3		5		3		6
			3		3		6		3
1		2		1					3
			3		5		3		6
			1						1
			2		1		2		2
			3		3				2



העצמה



רענון



חוויות



שיפור



גיבוש



מסעות



שטח



סדנאות ODT

2	4	5	2
	1		
2	4	5	1
3	5	1	2
4	3	2	3
	2	3	2
4	8	3	3
		2	2
1		2	3
	3		3
		2	1



העצמה



רענון



חוויות



שיפור



גיבוש



מסעות



שטח